



INSTALLATION INSTRUCTIONS

105 Broadway St. Belvue, KS 66407
Phone: 800-669-9867 Fax: 800-393-6699
www.onyxcollection.com

 **ALUMAX**
BATH ENCLOSURES
by Sapa
800-643-1514
www.alumaxshowerdoor.com



300CV Series

Semi-Frameless Hinged Door

300cv PARTS LIST

- | | |
|---------------------------------|----------------------|
| A.1 Shower Curb | K.2 Tubular Handles |
| B.1 Glazed Door Panel Assembly | L.4 Plastic Washers |
| C.2 Wall Jamb | M.2 Plastic Bushings |
| D.6 Plastic Wall Anchors | N.2 Cone Head Bolts |
| E.8 #8 x 2" Truss Head Screws | O.2 Set Screws |
| F.6 #6 x 3/8" Truss Head Screws | P.1 Deflector |
| G.1 Strike Jamb w/Magnet | |
| H.1 Latch Vinyl | |
| J.1 Latch | |

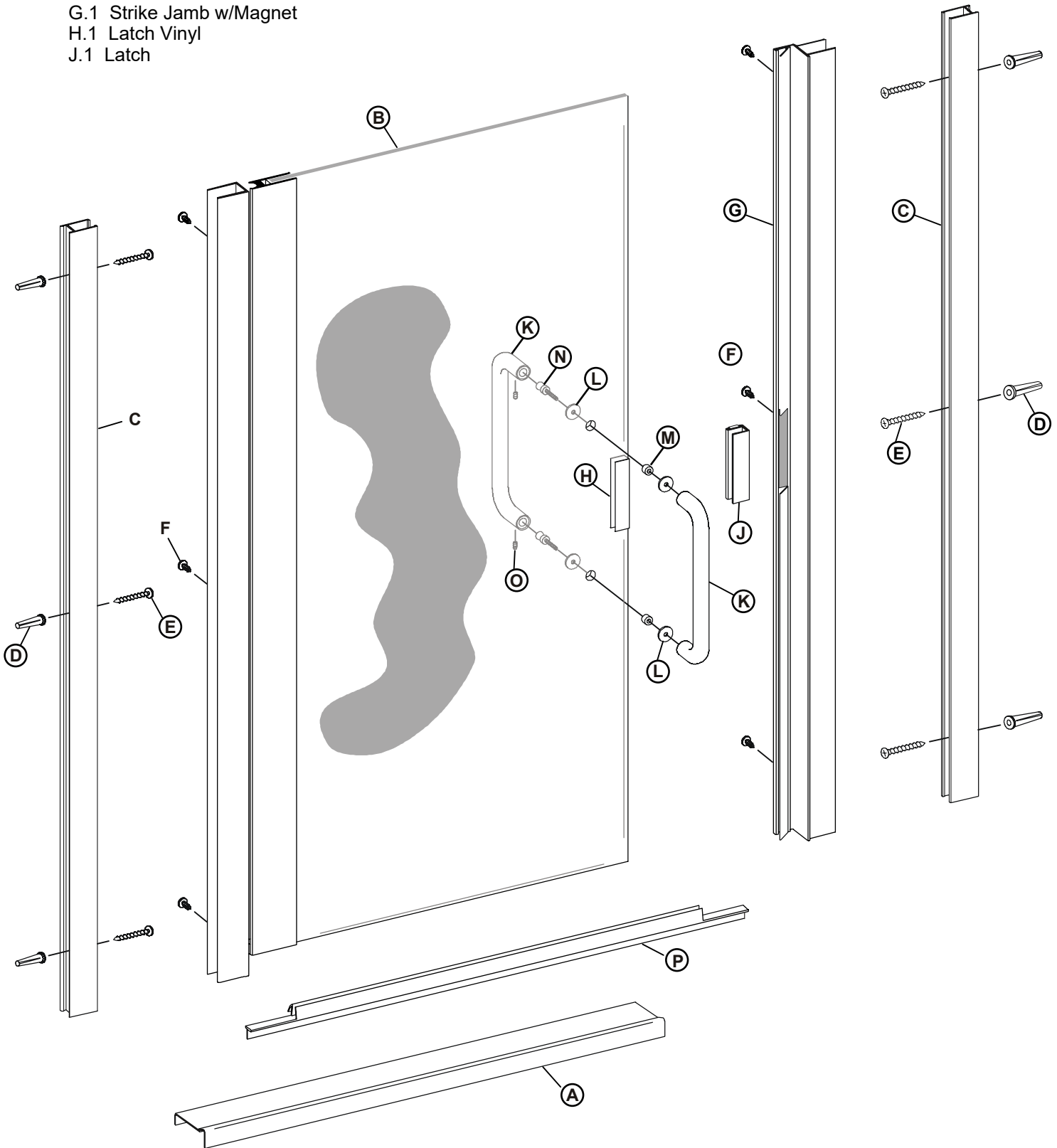

1 Refer to the illustration to determine the correct position for your installation. For maximum waterproofing, the hinge jamb should always be opposite the shower head. These instructions depict a hinge-left and hinge-right installation based on shower head location.

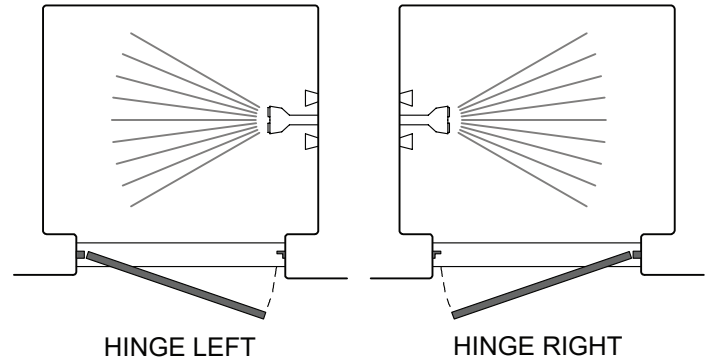

CAUTION: For safety, the door must always open outward.

2 **NOTE:** The 300cv unit may be installed without using the sloped curb [A] provided. Its use is definitely recommended for positive water control on shower sills with little or no slope.

Measure the wall-to-wall opening at the shower sill and cut the curb to the exact length. File the ends of curb as necessary to fit the corner contours of the enclosure.

Place the curb on the shower sill with the raised portion to the exterior of the enclosure. Make sure the curb is centered on the sill and lightly mark its position on the sill with a pencil.

Remove the curb from the sill and run two beads of silicone inside the penciled marks on the shower sill. Place the curb in the exact position marked and seat it firmly in the caulking.

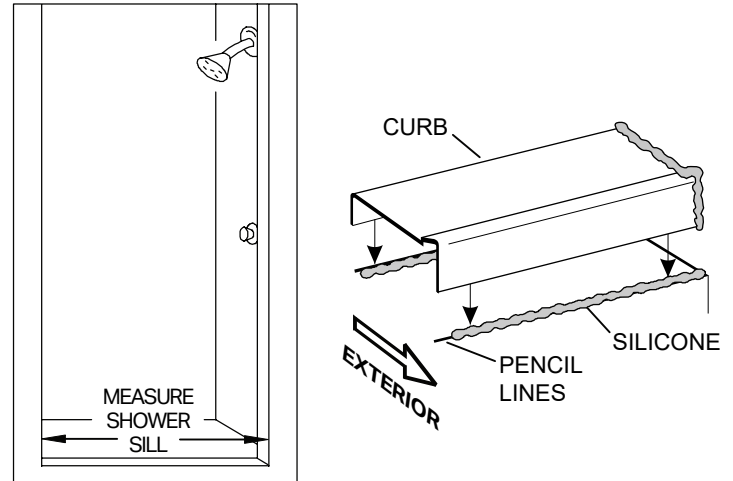

BE SURE THE SHOWER IS PROPERLY SILICONED BEFORE INSTALLING THE DOOR

3 Place the wall jamb [C] against the strike side wall with the bottom end $3/16$ " from the raised side of the curb [A]. Plumb the jamb and mark the hole locations on the wall. Repeat for the other wall jamb. Remove all parts and drill the walls for mounting hardware. For tile or marble walls, drill six $1/4$ " diameter holes and insert the plastic wall anchors [D]. Attachments to fiberglass or acrylic units can be made in two ways. If a reinforcement is built into the wall of unit, drill six $1/8$ " holes and install mounting screws directly into the reinforcement. If walls are not reinforced, drill $1/4$ " holes and install plastic wall anchors or toggle bolts (toggle bolts not supplied by Alumax).

Replace each wall jamb and attach them to the wall with three #8 x 2" truss head screws [E].

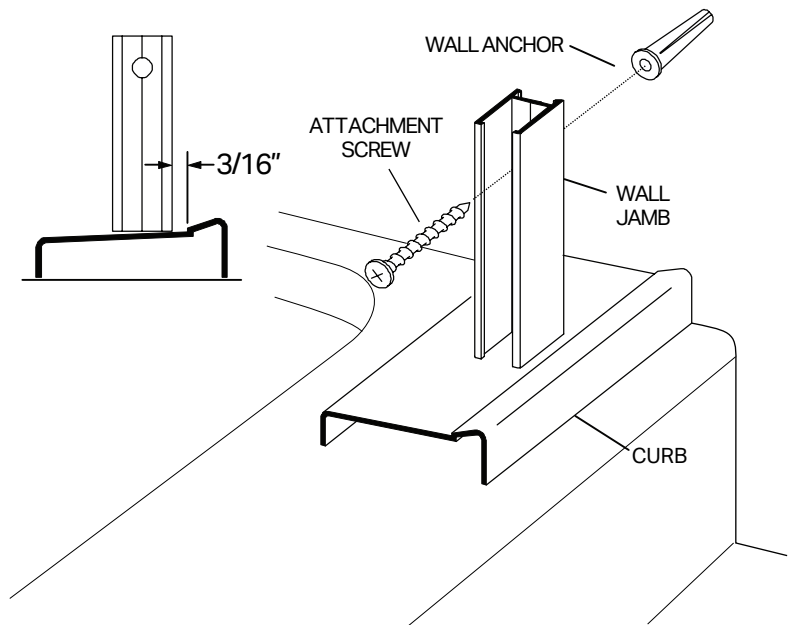

4 Slide the strike jamb [G] over one of the mounted wall jambs [C] with the magnet facing outward. Measure the wall-to-wall opening at the top and at the bottom of the wall jambs and note the smaller dimension. Measure the entire width of the door panel [B] from the outside edge of the side rail to the edge of the glass on the strike side. Add 2 1/4" to the door width, subtract the total from the minimum wall-to-wall opening and divide the result by two. This should be the distance from the wall to the strike jamb at the closest point. Plumb the strike jamb vertically and mark its location on the wall jamb with a pencil.

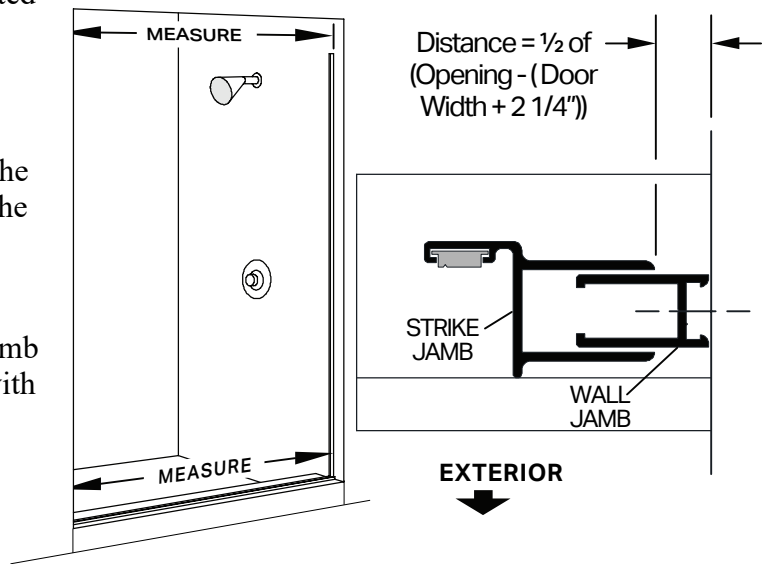

5 Inside the shower enclosure, drill two 1/8" holes thru the strike jamb [G] and into the wall jamb [C] 3/8" to 3/4" from the wall and approximately 1" vertically from each end of the strike jamb. Drill a third hole centered between the first two, then enlarge the three outer holes with a 3/16" drill for clearance on the self-tapping screws. Attach the strike jamb permanently with three #6 x 3/8" pan head screws [F].

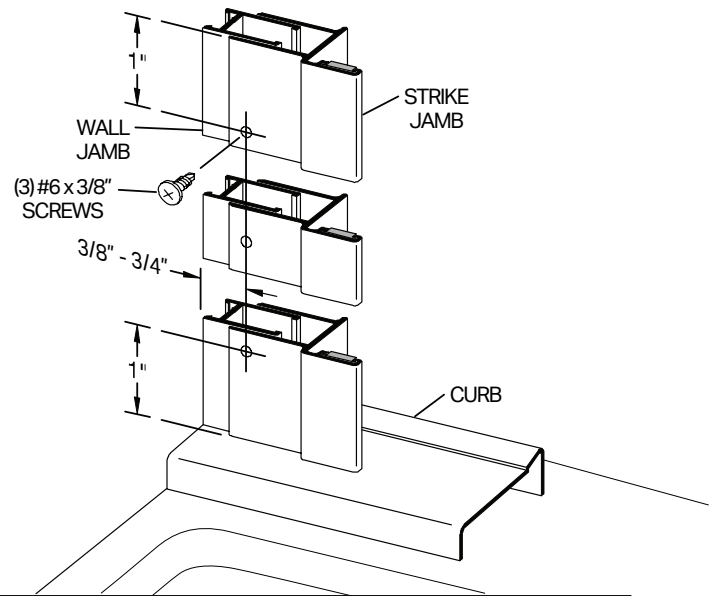

6 Slide the hinge jamb of the door panel assembly [B] over the mounted wall jamb [C] so the door will open outward. Adjust the door panel assembly so there is 1/4" clearance between the strike jamb and the strike edge of the glass door panel in the closed position. Mark the location of the hinge jamb on the wall jamb with a pencil.

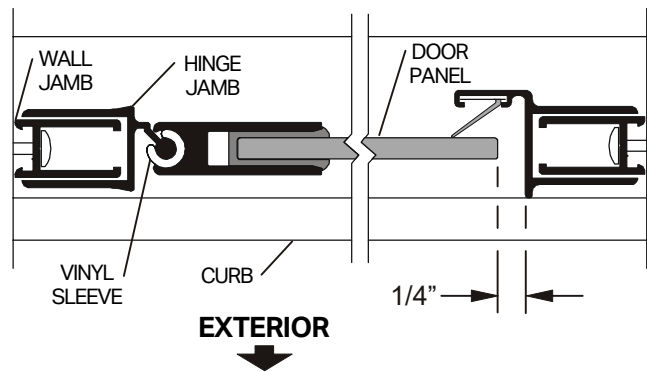

7

Inside the shower enclosure, drill two 1/8" holes thru the hinge jamb and into the wall jamb [C] 3/8" to 3/4" from the wall and approximately 1" vertically from each end of the hinge jamb. Drill a third hole centered between the first two, then enlarge the three outer holes with a 3/16" drill for clearance on the self tapping screws. Attach the door panel assembly permanently with three #6 x 3/8" pan head screws [F].

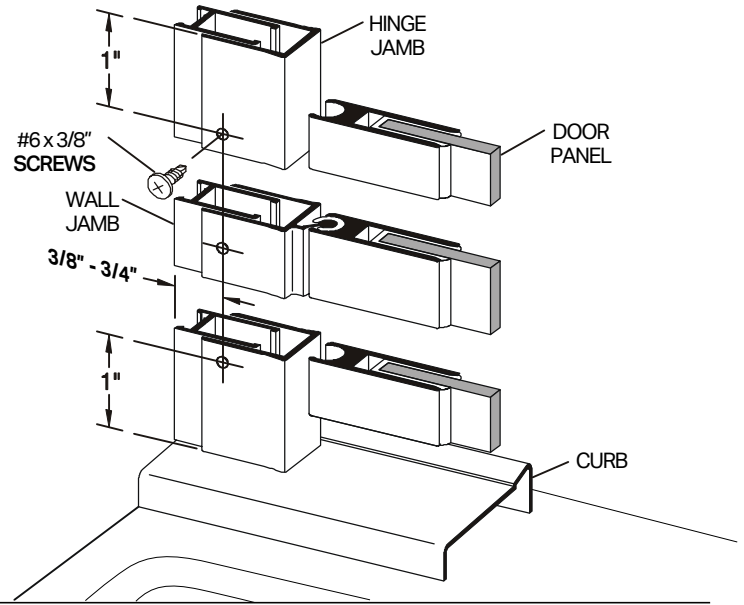

8

Slide the latch [J] with magnet onto the strike edge of the door panel. Close the door and slide the latch up or down until the two magnetic strips are aligned. Use a pencil or masking tape to mark the location of the latch on the door.

Wrap the latch vinyl [H] over the edge of the door glass between the marks and carefully drive the door latch onto the door panel. Spraying glass cleaner or water onto the vinyl will make assembly easier. Close the door and check for proper operation of the magnetic catch.

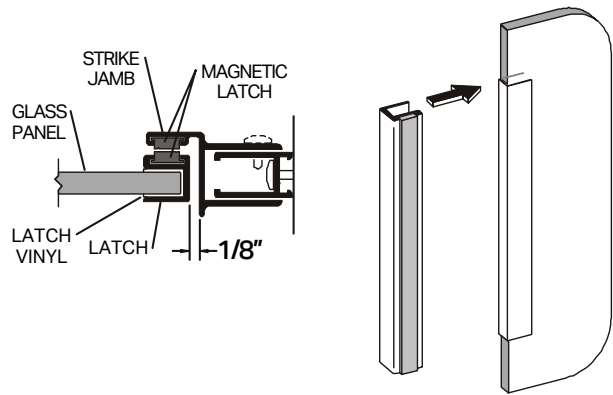

9

Determine the desired handing of the deflector [P]. The deflector leg must go to the inside of the unit and the notch fits under the hinge rail as shown in the drawing at right. To determine the door panel width measure the distance from the edge of the hinge rail to the far edge of the glass door panel. The deflector should be cut to Door Panel Width - 7/16". Press the deflector firmly on the bottom edge of the glass as shown. Apply a small bead of silicone to the notch that goes under the hinge rail.

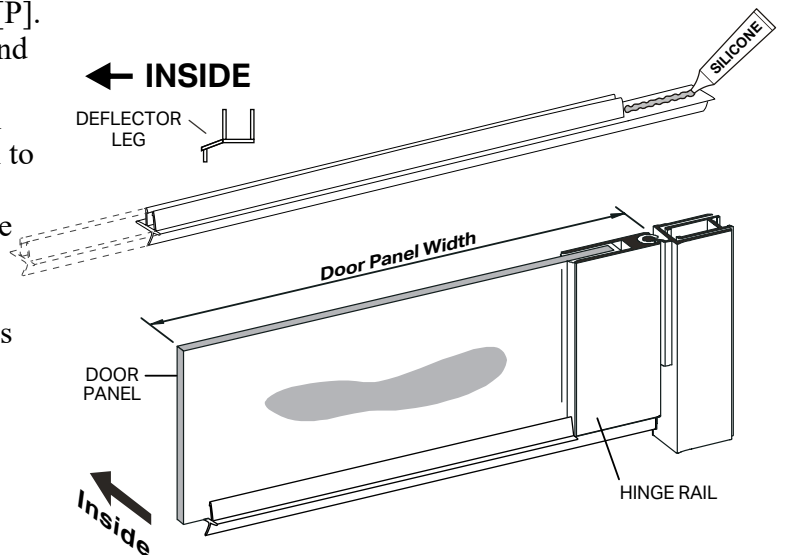

-
-
- 10** Locate the handle [K] that has no Set Screws. Place a Plastic Bushing [M] in the top handle hole then place a Plastic Washer [L] against the glass. Place the handle without Set Screws against the Plastic Washer and insert the threaded end of the Cone Head Screw [N] through the bushing into the threaded insert in the end of the handle and tighten. Repeat the procedure for the bottom hole. Place Plastic Washers [L] against the opposite side of the glass and press the remaining handle [K] over the end of the Cone Head Screw. While holding the handles firmly against the glass tighten the Set Screws [O].

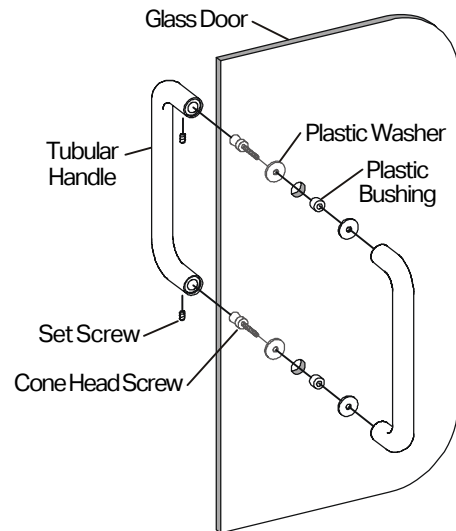

-
-
- 11** Neatly caulk the inside perimeter of the shower curb and the wall jambs. NOTE: Improper caulking will result in leaks. NOTE: The caulking should be allowed to cure for twenty four hours before using your new shower enclosure.

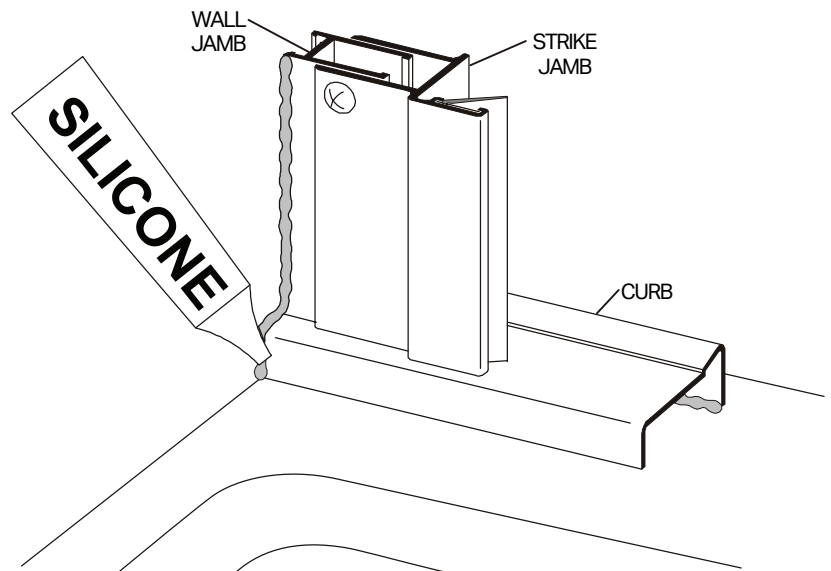

The Care and Cleaning of your new Alumax Bath Enclosure. The simplest and preferred method of cleaning your unit is by washing it with clean water and drying with a soft cloth. If soil is still present after drying, a non-abrasive cleanser with a pH of seven to eight may be used. Comet Bathroom Cleaner[®] has been tested and is recommended by the Bath Enclosure Manufacturers Association (BEMA). Do not use scouring pads, sharp instruments, or acid-based cleansers to clean the unit.